

COMMERCIAL Hood type Dishwasher (Model# : H60 series)



Intertek COMFORMS TO UL STANDARD 921 & CERTIFIED TO CSA STD C22.2 NO.168
5027459



SANITATION
NSF/ANSI 3

INSTRUCTION MANUAL

Read these instructions carefully before using your appliance, and keep it carefully.
If you follow the instructions, your appliance will provide you with many years of good service.

TABLE OF CONTENTS

1	Important Safety Instructions	1
2	Product Dimension	2
3	Names of Parts and Accessories	3
4	Operating Instructions	4-25
4.1	NOTES ON THE DOCUMENTATION.....	4
4.2	Layout of the documentation.....	4
4.3	Representative convention.....	4
4.4	SAFETY INSTRUCTIONS AND REGULATIONS.....	5
4.4.1	Safety instructions and warning notices	5
4.4.2	Hazard levels	5
4.4.3	Layout of warning notices.....	5
4.5	Basic safety instructions.....	5
4.5.1	Product safety.....	5
4.5.2	Personnel qualification.....	5
4.5.3	Product-specific hazards.....	6
4.6	Property damage.....	6
4.7	PRODUCT DESCRIPTION	6
4.8	General	6
4.9	Designation	7
4.10	Technical specifications.....	7
4.11	CONTROLS	8
4.12	INSTALLATION	9
4.12.1	Personnel qualification	9
4.12.2	Special safety instructions	9
4.12.3	Transporting to the installation location	9
4.12.4	Unpacking.....	9
4.13	Installing the machine	10
4.13.1	Installation Codes.....	10
4.13.2	Attaching legs	10
4.13.3	Location	10
4.13.4	Corner Installation.....	11
4.13.5	Rack guide installation.....	11
4.14	Connecting the water.....	12
4.14.1	Water Requirements.....	12
4.14.2	Water Connection	12-13
4.15	Connecting the drain	14-15

4.16	Venting Requirements	16
4.16.1	Rate of Exhaust Flow Calculations.....	16
4.17	Connecting to the power supply.....	17
4.17.1	Electrical Data	17
4.17.2	Electrical Connection (H60-DT/ST/CT/H60-D1/S1/C)	18
4.17.3	Electrical Connection (H60-DT2/ST2/CT2)	19
4.18	CHEMICAL SUPPLY SET UP	20
4.18.1	Personnel qualification	20
4.18.2	Checking the chemical supply tubing	20
4.18.3	Setup of external chemical bottles/buckets	20
4.18.4	Filling chemical tubing.....	20
4.19	OPERATION	21
4.19.1	Personnel qualification.....	21
4.19.2	Special safety instructions.....	21
4.19.3	Notes for optimal washing result.....	21
4.19.4	Preparation for washing.....	21
4.19.5	Preparing the ware for washing.....	22
4.20	Washing.....	23
4.21	Switch off machine.....	23
4.22	Daily cleaning or after each meal period.....	23
4.23	SETTINGS.....	24
4.23.1	Overview of operator menu.....	24
4.23.2	Opening the operator menu.....	25
4.24	Detergent and Rinse Aid Dispensing.....	26
4.24.1	Setting detergent dispensing.....	26
4.24.2	Setting rinse aid dispensing.....	26
4.24.3	Priming detergent and rinse aid dispensing pump.....	26
5、	Cleaning and Maintenance	27
5.1	Weekly cleaning	27
5.2	Removing hard water deposits (Deliming) 	27
6、	Troubleshooting	28
6.1	Informationr	28
6.2	TROUBLESHOOTING GUIDE	29
Warranty	End

Customer Care

Thank you for purchasing a our company product. Please read the entire instruction manual before operating your new appliance for the first time, Whether you are an occasional user or an expert, it will be beneficial to familiarize yourself with the safety practices,features, operation and care recommendations of your appliance.

Both the model and serial number are listed inside the product. For warranty purposes, you will also need the date of purchase .

Record this information below for future reference.

Product Information

Model Number : _____

Serial Number :

Date of Purchase : _____

Purchase Address And Phone : _____

Service Information

Use these numbers in any correspondence or services calls concerning your product.

If you received a damaged product, immediately contact our company.

To save time and money, before you call for serviced, check the troubleshooting guide. It listed the causes of minor operation problems that you can correct yourself.



WARNING FOR YOUR SAFETY

Your safety and the safety of others are very important.

We have provided many important safety messages in this manual and on your appliance. Always read and obey all safety messages.



This is the safety alert symbol. This symbol alerts you to potential hazards that can kill or hurt you and others. All safety messages will follow the safety alert symbol and either the word "DANGER," "WARNING" or "CAUTION." These words mean:



DANGER

- You can be killed or seriously injured if you don't immediately follow instructions.



WARNING

- You can be killed or seriously injured if you don't follow instructions.



CAUTION

- A potentially hazardous situation which, if not avoided, could result in minor or moderate injury.

All safety messages will tell you what the potential hazard is, tell you how to reduce the chance of injury, and tell you what can happen if the instructions are not followed.



WARNING :This product can expose you to chemicals including [Lead, lead and lead compound, which is [are] known to the state of california to cause cancer and birth defects or other reproductive harm. For more information go to www.P65Warning.ca.gov.



WARNING FOR YOUR SAFETY

This chapter provides you with important safety notices when handling the device.

The device corresponds with the required safety regulations. Improper use can result in personal or property damages.

Please read the information contained herein so that you can become familiar with your device quickly and take advantage of the full scope of its functions.

! WARNING

A warning notice of this level of danger indicates a possible dangerous situation.

If the dangerous situation is not avoided, this can lead to serious injuries.

b observe the instructions in this warning notice in order to avoid the personal injuries.

! WARNING

A warning notice of this level of danger indicates a possible dangerous situation.

If the dangerous situation is not avoided, this can lead to slight or moderate injuries.

b observe the instructions in this warning notice in order to avoid the personal injuries.

PLEASE NOTE

A notice of this kind indicates additional information, which will simplify the handling of the machine

1. The earth wire has been connected to the power plug, please do not alter the power plug without authorization. It must use a reliable power outlet when connecting the power supply.
2. Do not put the power socket and other equipment on the top of the unit, do not put packaging and any combustible around the unit, so as to avoid accidental fire.
3. Do not operate this device if its power cable or plug is damaged, if it does not work properly or if it is damaged or has been dropped. If the power cable is damaged, it will need to be replaced by the manufacturer or his service agency or a similar qualified person, to avoid any dangers.
4. Do not open the housing on the device under any circumstances. There is a danger of an electrical shock if live connections are touched and the electrical or mechanical structure is altered. In addition, functional faults on the device can also occur.
5. The equipment must be maintained by professional maintenance personnel, there is no repair parts inside the unit.
6. Used product need to be recycled by specialized companies, do not arbitrarily discarded. The door and shelf need to be disassembled before discard.
7. Please use the product at the appropriate ambient temperature according to the climate type on the product nameplate. Abnormal temperature and frost may occur when the temperature range of the corresponding climate type is exceeded.

SN	+10° C~+32° C (+50° F~89° F)
N	+16° C~+32° C (+61° F~89° F)
ST	+16° C~+38° C (+61° F~100° F)
T	+16° C~+43° C (+61° F~109° F)
SN-ST	+10° C~+38° C (+50° F~100° F)
SN-T	+10° C~+43° C (+50° F~109° F)

1. Important Safety Instructions

- This appliance couldn't share a socket with other appliance, otherwise, it is easy to cause short circuit or damage the electronic components.
- Do not squeeze the power plug, it will cause fire or electric shock if it is damage.
- Ensure the grounding wires connect correctly. If ignore this, it will has the possibility to cause the receiving an electric shock accident or equipment failure.
- Do not damage, prick, twisting, stretching the power cord, it may result in fire or electric leakage if the power cord is damaged.
- cannot lengthen the power cord without authorization, otherwise, it is easy to cause short circuit or damage the electronic components.
- Before changing the inner light, turnoff the appliance first and then unplug the unit from the wall outlet.
- Check the plug whether has dust or foreign matter, then, plug in firmly.
- Clean the dust on the plug regularly to reduce the possibility of fire.
- Before cleaning, switch the device off, remove the plug from the wall socket and keep the hand dry.

WARNING

The equipment must be maintained by professional maintenance personnel, otherwise, it may cause injury, electric shock or fire and will loss of warranty.

Do not climb the cabinet, otherwise, the equipment will overturned, especially keep it away from children.

WARNING

Do not place heavy objects on the top of the cabinet, or they may falloff when the device is opened and causing injury.

Never use the device to store flammable materials, such as benzene, ether, alcohol. otherwise, there could be an explosion.

Do not store the objects which is sensitive to temperature changes, such as medications or chemicals, otherwise, deterioration or accident may occur.

Do not put vases, glassware or any container with liquid on the top of equipment, it might cause electrical leakage or other damage when the liquid splashed on electronics.

Do not use flammable sprays around the equipment. sparks from electrical or control circuits may cause a fire or explosion.

Do not pour the liquid directly onto the device when cleaning. Liquid can cause the equipment short circuit or electricity leakage, even fire.

keep the equipment away from the open flame and high temperature place.

The equipment is only allowed to be used as household appliances and cannot withstand harsh conditions and can't install on recreational vehicles or ships.

Do not touch the equipment or power cord if you found gas

leakage, evacuate immediately and call fire department on 911 phone.

WARNING: Keep ventilation openings, in the appliance enclosure or in the built-in structure, clear of obstruction.

WARNING: Do not use electrical appliances inside the equipment, unless they are of the type recommended by the manufacturer

ATTENTION

- Grasp plug and pull out from the socket when pull out the power plug, never pull the power cord.
- If you do not use the equipment for a fairly long period of time, you should pull out the plug, remove all the shelves , clean the equipment thoroughly and keep the door open for 48 hours.
- Do not operate this device if its power cable or plug is damaged, if it does not work properly or if it is damaged or has been dropped. If the power cable is damaged, it will need to be replaced by the manufacturer or his service agency or a similar qualified person, to avoid any dangers.
- Do not place the equipment where it can collide with furniture or other objects.
- Do not put your hand to the metal base which is under the equipment, otherwise, the sharp edges on the metal base may cause harm to you.
- Transport, unpack and use two or four persons to set down the device because of the heavyweight of the device. Be sure to move the equipment vertically.

2、 Product Dimension

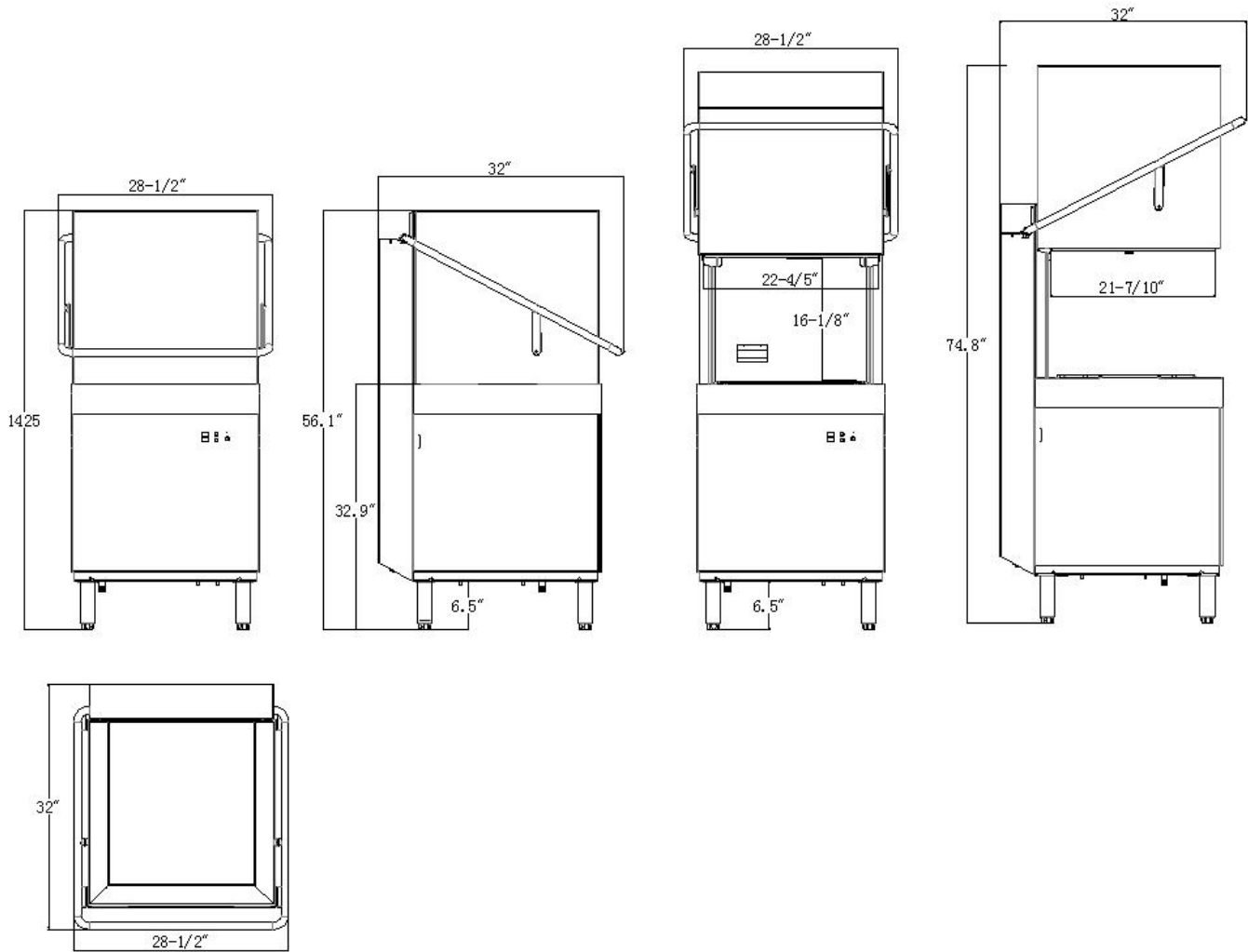

A	B	C	D	E
Total width	Total height	Height (top to bottom)	Total depth (from handle to back)	Height of the storage frame above the ground
$28\text{-}1/2''$	$56.1''$	$49\text{-}1/2''$	$32''$	$31\text{-}1/2''$
F	G	H	I	J
Effective washing width	Effective washing depth	Effective washing height	Effective washing height	Handle width
$22\text{-}4/5''$	$21\text{-}7/10''$	$16\text{-}1/8''$	$74.8''$	$28\text{-}1/2''$

3、 Names of Parts and Accessories

1	Upper cover	14	Water level switch
2	Door pull rod	15	Main wash pump
3	Front sealing plate	16	Built-in dispenser
4	Adjustable support feet	17	Rinse pump
5	Right sealing plate	18	Booster
6	Rear sealing plate	19	Rinse heating element
7	Left sealing plate	20	Lower connection T-piece
8	Bottom drainage flange	21	Wash arm
9	Drainage filter screen	22	Rinse arm
10	Drainage rod	23	Up connection T-piece
11	Main wash heating element	24	Rear connection T-piece
12	Main washing filter screen	25	Inlet solenoid valve
13	Control box		

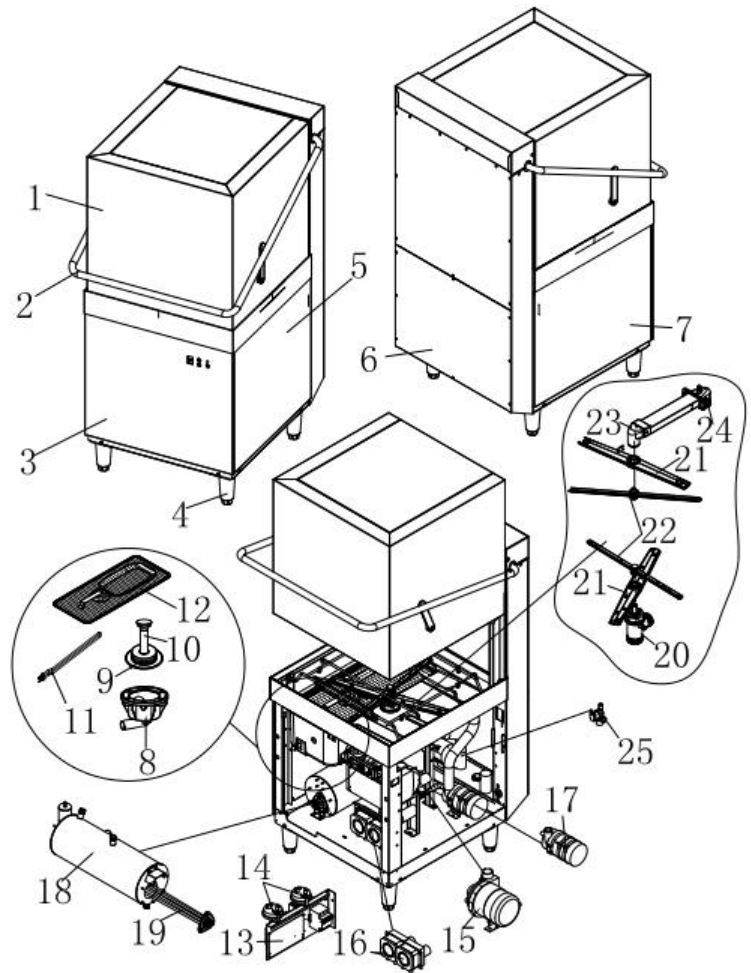

Supplied Parts

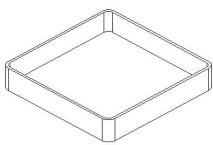
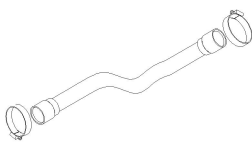
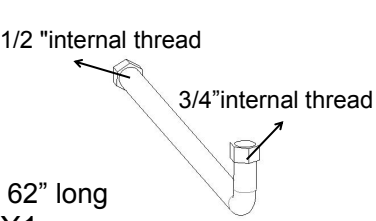
Rack guides	Peg Rack	Drain hose	Water supply hose
 <p>L x W x H 24"x20.67"x3.15" X1</p>	 <p>L x W x H 19.3"x19.3"x4" X2</p>	 <p>62"long 0.75" inside diameter X1</p>	 <p>1/2 "internal thread 3/4" internal thread 62" long X1</p>

4. Operating Instructions(continued)

4.1 NOTES ON THE DOCUMENTATION

This document contains important information for the installation and startup of the machine by qualified personnel, as well as the information required for day-to-day operation by the operator.

- ▶ Keep the operating instructions and all referenced documents in a safe and accessible place.



This Installation and Operations manual is subject to change.

4.2 Layout of the documentation

Referenced documents are all instructions that describe the installation, operation, maintenance, and repair of the device, as well as additional instructions for all accessories used.

For the operator:

- Operating instructions

For the qualified technician (available online):

- Installation instructions
- Circuit diagram
- Spare Parts Catalog

4.3 Representative convention

Symbols used

Symbol	Meaning
	Warning of hazardous electrical voltage
	Beware of pressure hand
	Pay attention to high temperature to prevent splash injury

4. Operating Instructions(continued)

4.4 SAFETY INSTRUCTIONS AND REGULATIONS

4.4.1 Safety instructions and warning notices

During machine operation, observe the general safety instructions and warning notices that precede each action.

4.4.2 Hazard levels

The hazard level is part of the safety instructions and is denoted by the signal word. Potential consequences are differentiated by the choice of signal word.

 WARNING	potentially hazardous situation: can cause serious physical injury
NOTICE	potentially harmful situation: can cause damage to the product or other objects

4.4.3 Layout of warning notices

Warning notices are depicted with warning symbols and signal word in the corresponding safety colors.

 **WARNING!**



Nature and source of the hazard

Explanation on the nature and source of the hazard.

Measures for averting the hazard

Additional measures for averting the hazard, where applicable.

4.5 Basic safety instructions

4.5.1 Product safety

The machine conforms to state-of-the-art technology and the recognized safety regulations. Nonetheless, hazards may occur.

Operate the machine only if it is in good working order and in compliance with the operating instructions.

4.5.2 Personnel qualification

Observe the regulations on occupational health and safety.

Carefully read through the operation manual before use.

Activity	Qualification/training
Installation/Setup	Qualified electrician and plumber
Work on the electrical system	Qualified electrician
Maintenance, repair	Qualified service technician

4、 Operating Instructions(continued)

4.5.3 Product-specific hazards

Observe the instructions on the packaging for storage, lifting or transporting.

Avoid electric shock, risk offire:

Do not allow water to flow under live components.

- Make sure the machine is correctly stored (see frost damage section2.3).
- Make sure that the machine does not overflow when being filled.

Have the machine connected to the power supply by qualified personnel.

Have all maintenance to the machine carried out by qualified personnel.

Avoid chemical burns, irritation of the skin, poisoning:

Wear protective equipment (gloves, safety goggles, protective clothing) when handling chemicals.

Use only suitable chemicals. Observe the manufacturer's instructions.

Do not open the machine during operation, wait for the cycle to finish.

For cleaning, wear protective equipment (gloves, safety goggles, protective clothing) when touching parts contaminated by detergent.

Avoid burns, scalds:

Do not open the machine during operation, wait for the cycle to finish. Otherwise, hot water could spray out.

4.6 Property damage

Avoid frost damage:

Temperatures below 32°F (0°C) lead to functional damage.

Before storing below 32°F (0°C), empty residual water in hoses, tank and booster.

Prior to restart, store the machine at room temperature (min. 60°F / 15°C) for 24 hours.

4.7 PRODUCT DESCRIPTION

The machine is an item of technical equipment intended solely for commercial dish-washing.

The machine is designed solely for cleaning ware (porcelain, glass, ceramic, temperature-resistant plastics, stainless steel or similar) from the food industry.

4.8 General

The dishwashers can be configured for both straight through or corner operation and they are shipped from the factory in straight through configuration. Straight through machines can be easily converted to corner operation. The dishwashers are designed to operate in high temperature sanitizing mode only (Designated by the temperature requirements of 160°F Wash and 180°F Rinse. These temperatures can be found on the label located on the lower, left part of the front panel).

The serial number can be found on the machine data label located at the bottom of the right side of the machine.

4、 Operating Instructions(continued)

Detergent rinse acid pumps are built-in

The wash pump motor has thermal overload protection.

The unit, once turned on, fills the wash tank to the appropriate level and automatically stops filling once the level is reached. A pressure transducer reads the water level in the wash tank and shuts off the heat supply if the water level becomes too low. When the water returns to the proper level, the heating circuit becomes operational again.

A pumped rinse system is available.

A frame mounted 12.0kW electric booster water heater is equipped on the model. The booster water heater is designed to maintain a minimum final rinse temperature of 180°F provided the incoming water is at least 110°F.

High-temperature models typically require a hood or vent over the dishwasher to meet local codes.

Low-temperature chemical sanitizing machines or low usage electric heat dishwashers may not require individual venting of the machine if the room is amply exhausted. Refer to section 5.8 for venting and hood requirements. Verify with local codes for final authority.

4.9 Designation

The rating label is located on the right side of the machine. If you have any questions regarding service and parts, use the serial number in all communications.

4.10 Technical specifications

Model	H60-DT/ST/CT	H60-D1/S1/C	H60-DT2/ST2/CT2
Dimensions (W x D)	28.54”*32”	28.54”*32”	28.54”*32”
Dimensions (H)	56.1”	56.1”	56.1”
Water consumption per cycle	2.5L	2.5L	2.5L
Phase / Hz	3Ø / 60Hz	3Ø / 60Hz	1Ø / 60Hz
Voltage	208~240V	208~240V	208~240V
Total connected load	36.8A	28A	32A
Fuse/breaker protection	40A	40A	40A
Tank capacity	26L	26L	26L
Loading height	31.5”	31.5”	31.5”
Machine weight	102kg	102kg	102kg

4.11 CONTROLS

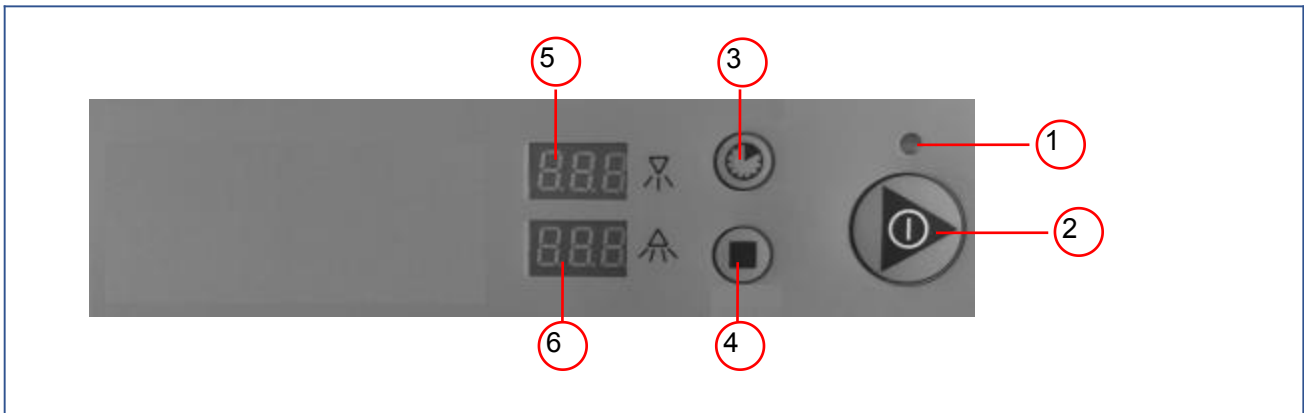

①	Indicator	Blue flashing indicates adding water; No status, indicating rinsing and heating; Red is constantly on, indicating that the main wash is heated; Green constantly on, indicating completion of heating and standby mode; The combination of green and blue is always on, indicating that the door is open; Green flashing indicates the cleaning process; Blue flashing indicates the rinsing process.
②	On	Pressing this button machine startup. Once machine fills and heats ready, closing the door starts the wash cycle. Pressing this button to confirm in menu setting.
③	Function	Short Pressing this button to select washing cycle, (cycle1 70s/ cycle2 100s/cycle3 130s) Holding this button by 7s, enters the configuration menu. Pressing this button to adjust parameter under setting status
④	Off	Pressing this button switch off the machine. Pressing this button to adjust parameter under setting status. After pressing this button, the device enters the automatic drainage program and automatically shuts down after completion. (Only applicable to H60-ST/H60-CT/H60-S1/H60-C/H60-ST2/H60-CT2 model)
⑤	Rinse Temp	Displays rinse temperature while machine is idle and displays remain timing in rinse cycle.
⑥	Washing Temp	Displays wash tank temperature while machine is idle and displays remain timing in wash cycle.

4.12 INSTALLATION

4.12.1 Personnel qualification

Installation must only be carried out by qualified personnel.

4.12.2 Special safety instructions

WARNING!

Risk of electric shock, fire hazard

Water flowing over live components can cause injury from electric shock or fire.

Do not allow water to flow under live components.

Make sure the machine is correctly stored.

NOTICE!

Frost damage

Temperatures below 32°F (0°C) during transport/storage cause function impairments.

Prior to installation, store machine at room temperature (min. 60°F / 15°C) for 24 hours.



4.12.3 Transporting to the installation location

Where possible transport packed on the pallet.

Use suitable transport means (forklift or hand truck, etc.).

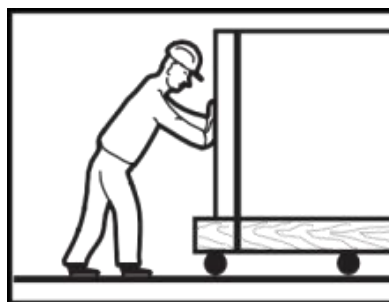

4.12.4 Unpacking

Remove packaging materials and accessories from the machine.

Packaged in machine

- Peg rack
- Literature pack
 - ⇒ Installation and operations manual
- Rack guide (1x)
- Water supply hose • drain hose

4. Operating Instructions(continued)

Immediately after unpacking the dishwasher, check for possible shipping damage. If this machine is found to be damaged, save packaging materials and contact the carrier within 5 days of delivery.

NOTICE!

Unpacking

Use caution when using a forklift to remove machine from pallet. Do NOT use door lift handle to move machine, as it will cause door lift issues.

4.13 Installing the machine

Prior to installation, test the electrical supply to ensure it agrees with the specifications on the machine data label, which is located on the lower, right side of the machine.

4.13.1 Installation Codes

Installation must be in accordance with state and local codes and the National Electrical Code ANSI/NFPA70 (latest edition). In Canada, the installation code is CSA 22.1 (latest edition).

4.13.2 Attaching legs

The machine is shipped with the legs

The machine must be level to operate properly. Place the dishwasher in its operation location. Level the machine before any connections are made.

Using a carpenter's level placed diagonally on the rack tracks, level the machine front to back and side to side by turning the adjustable feet in or out.

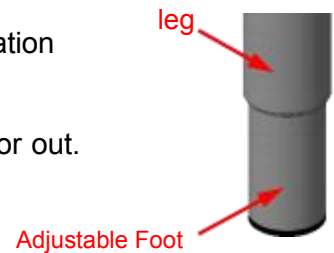

4.13.3 Location

Before finalizing the location, make sure that consideration has been given for the electrical conduit, water supply, drain connection, venting (if applicable), tabling (if needed), chemical feeder replenishment (if applicable) and adequate clearance for opening the door.

The edge of dish table that overhangs the machine wash tank should be turned down and fitted over the top of the dishwasher tank. Apply an NSF approved sealant between the overhang of the dish table and the inner wall of the wash tank to prevent leakage.

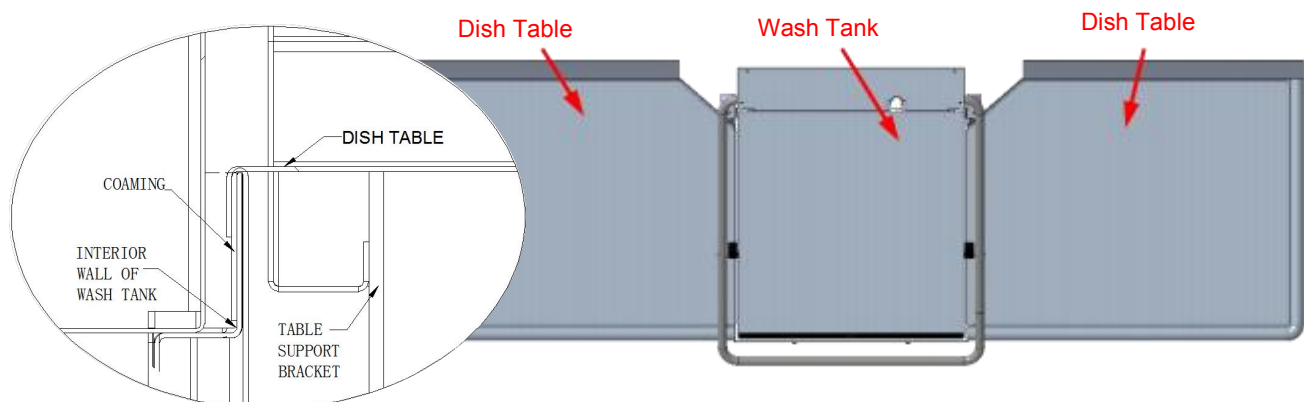

4. Operating Instructions(continued)

For straight-through installations, 30" clearance at the front and 15" clearance at the right side by 33 - 1/8" clearance above the finished floor must be provided for service.

4.13.4 Corner Installation

Before placing the dishwasher in its operating location, check machine configuration. If the machine is being installed in a corner, clearances of 30" out from the dishwasher under the left-hand tabling by 33- 1/8" above the finished floor and 15" out from the dishwasher at the right side by 33-1/8" above the finished floor must be provided for servicing. For proper installation of a corner machine, the right corner of the machine should be positioned where the two tables meet so that the gauges (if equipped) are visible to the operator.

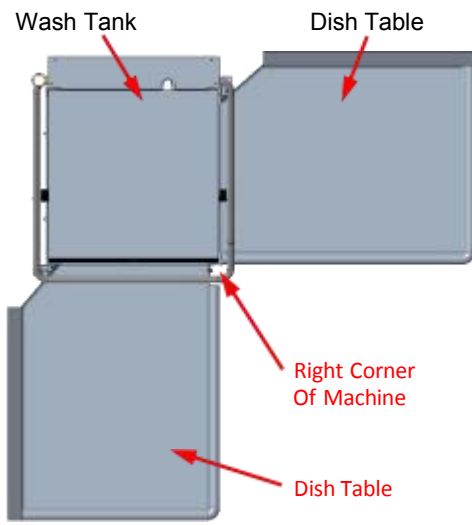

Corner Operation Shown

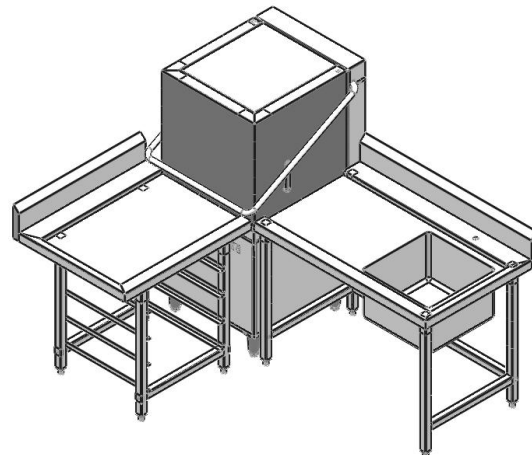

CDL Shown

4.13.5 Rack guide installation

For straight-through installations,

Position rack guides on front side and the backside of the rack track aligning holes in rack guide to spacers on rack track.

Secure using included hardware. Note: Nuts should be installed on the inside of the rack track.

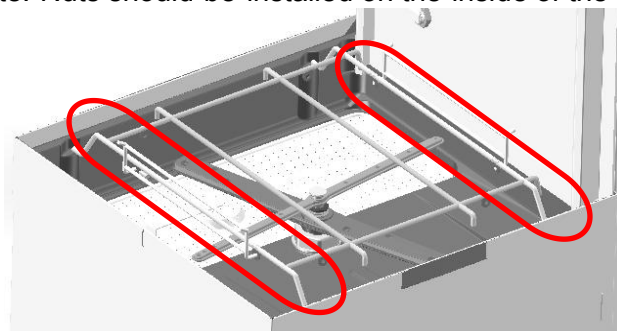

4、 Operating Instructions(continued)

For corner installations,

Position rack guides on left side and the backside of the rack track aligning holes in rack guide to spacers on rack track.

Secure using included hardware. Note: Nuts should be installed on the inside of the rack track.

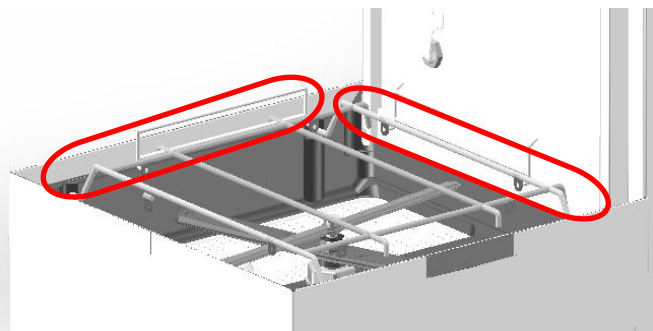

4.14 Connecting the water

NOTE: The machine must be operated with potable water.

4.14.1 Water Requirements

Proper water quality can improve ware washing performance by reducing spotting, enhancing effectiveness of labor, and extending equipment life. Water conditions vary from one location to another. The recommended proper water treatment for effective and efficient use of this equipment will also vary depending on the local water conditions. Ask your municipal water supplier for details about your local water conditions prior to installation.

Recommended water hardness is 3 grains of hardness per gallon or less. Higher hardness may cause excessive formation of lime scale. Water hardness above 3 grains per gallon requires water treatment. Water treatment has been shown to reduce costs associated with machine cleaning, reduce deliming of the dishwasher, and reduce detergent usage in the dishwasher.

NOTICE!

Water quality

High iron levels in the water supply can cause staining and may require an iron filter. High chloride levels in the water supply can cause pitting and may require a chloride removal system. Contact our company Service or your local water treatment professional for proper water treatment.

Sediment may require a particulate filter. Dissolved solids may require water treatment such as a water softener, reverse osmosis system, etc. Contact our company Service or your local water treatment professional for proper water treatment.

4.14.2 Water Connection

A water hammer arrestor (meeting ASSE-1010 Standard or equivalent) should be installed (supplied by others) in the common water supply line at the service connection.

The plumber connecting this machine is responsible for making certain that waterlines are

4. Operating Instructions(continued)

THOROUGHLY FLUSHED OUT BEFORE connecting to the dishwasher. This "flush-out" is necessary to remove all foreign matter, such as chips (resulting from cutting or threading of pipes), pipe joint compound from the lines; or, if soldered fittings are used, bits of solder or cuttings from the tubing.

Debris, if not removed, may lodge in the dishwasher's plumbing components and render them inoperative. Solenoid valves fouled by foreign matter and any expenses resulting from this fouling are NOT the responsibility of the manufacturer and associated repair costs are not covered under warranty.

A manual shutoff valve (not supplied) should be installed upstream of the fill hose to accommodate servicing the machine. It is recommended that a line strainer (80 mesh) (not supplied) be installed in the supply line between the manual shutoff valve (not supplied) and the connection point on the machine. Make plumbing connections with 1/2" minimum copper piping OD (3/4" recommended), with a 3/4" male garden hose fitting (not supplied).

Connect to hot water

A water supply hose is provided.

Temperature:

Model	Sanitizing Mode	Connection	Water Supply		
			Minimum	Maximum	Recommended
H60 series	High temperature Sanitizing	Hot Water	110°F (43°C)	N/A	140°F (60°C)

Water hardness: max. 3 grains

Flowing pressure:

Model	Flowing Pressure	Note
H60 series	28 psi – 58 psi (2 bar – 4 bar)	Recommended
	> 65 psi (4.5 bar)	Provide pressure regulating valve (not supplied)
	< 15 psi (1 bar)	Improper machine operation may result
	Water pressure gauge is not required	

The supply hose, 62" long, 3/4" internal thread and 1/2" internal thread, is provided with the machine.



4. Operating Instructions(continued)

Find the water connection label at the bottom of rare panel and connect the end of water supply hose 3/4" thread to machine, and connect the end of the water supply hose (1/2" garden hose thread) to the building shut off valve.

Note that:

- Use care not to kink or cut the water supply hose.
- Any required extension must be made using a suitable pressure hose.
- A check valve that meets the requirements needs to be installed at the front end of the solenoid valve (provided by the customer)

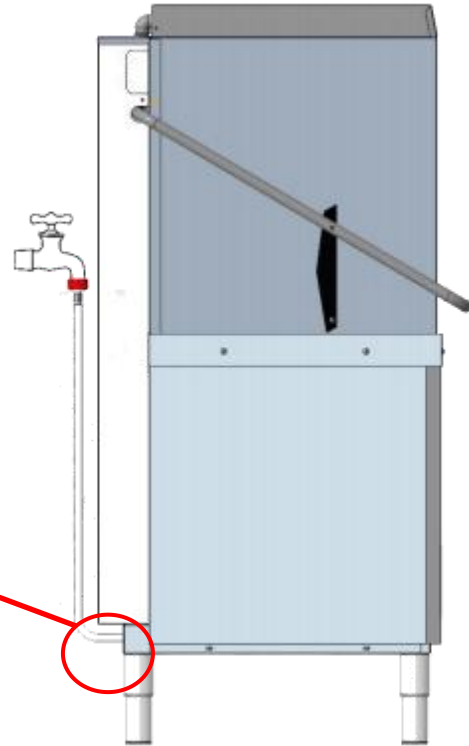
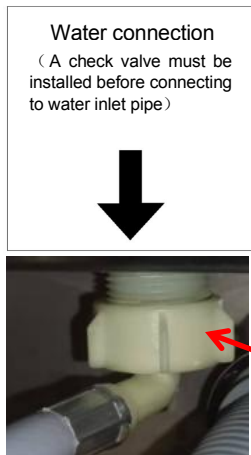

4.15 Connecting the drain

A drain hose, 0.75" inside diameter and 62" long, is provided with the machine and is shipped attached and coiled up inside the machine.

⚠ WARNING!

Plumbing connections

Plumbing connections must comply with applicable sanitary, safety, and plumbing codes.

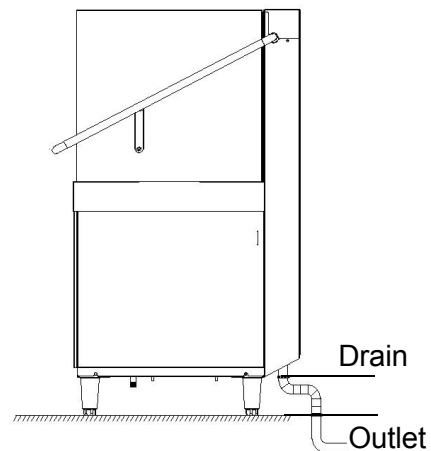

4. Operating Instructions(continued)

Note that:

- The connection between machine and building drain must not exceed a maximum height of 5.1" above finished floor.
- Drain must have a minimum flow capacity of 5 gallons per minute.
- If a grease trap is required by code, it should have a minimum flow capacity of 15 gallons per minute.
- If machine is located directly above a floor drain, a knockout in the bottom of the dish machine is provided for the drain hose.
- Use care not to kink the drain hos

NOTICE!

Drain connection

An improper drain connection or a kinked hose could result in reduced machine performance and errors. An air gap connection is the preferred connection method.



Incorrect
Acceptable



Preferred
(Meets Code Requirements)



4. Operating Instructions(continued)

4.16 Venting Requirements

NOTICE!

Exhaust Hood

Any commercial exhaust hood must be installed according to all local and national codes and the manufacturer’s installation instructions, if applicable.

4.16.1 Rate of Exhaust Flow Calculations

Based on the 2018 International Mechanical Code.

The minimum net airflow for Type II hoods used for dishwashing appliances shall be 100 cfm per linear foot of hood length. The net quantity of exhaust air shall be calculated by subtracting any airflow supplied directly to a hood cavity from the total exhaust flow rate of a hood.

According to 507.3 of the 2018 IMC, Type II hoods are not required where the heat and moisture load is incorporated into the HVAC system design. See *Table A* for heat dissipation or heat gain to space.

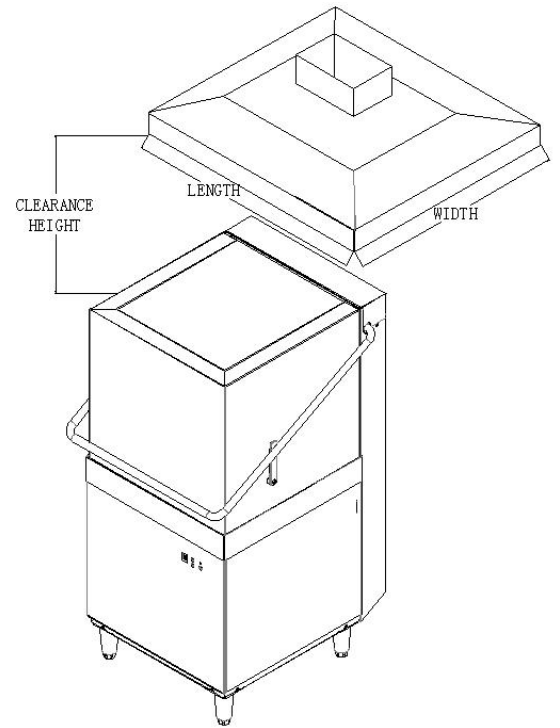

Table A: HEAT DISSIPATION

Model	Sanitizing Mode	Voltage	Phase	Electric Heat	Electric Booster	Latent Heat (BTU/Hr)	Sensible Heat (BTU/Hr)
H60 series	High Temperature	208V	3Ø/ 1Ø	X	X	16,100	6,900
		240V		X	X	20,400	8,700
Assumptions: 1. Machines operate 70% of each hour while in use. 2. Values shown are heat that enters room. 3. 70% of heat output is latent, 30% is sensible.							

4.17 Connecting to the power supply

⚠ WARNING!



Risk of electric shock

Electrical and grounding connections must comply with the applicable portions of the National Electrical Code, NFPA 70 (latest edition) and/or other local electrical codes.

Disconnect the electrical power to the machine and follow lockout/tagout procedures.

4.17.1 Electrical Data

Refer to the sizing diagram located inside the front trim panel and to the data label on the lower, right side of the machine for service size requirements when connecting the dishwasher. Also, refer to the Electrical Data, shown below.

NOTICE!

Supply connections

For supply connections, use copper wire only rated at 90°C minimum.

The dish machine is not provided with internal GFCI protection.

A fused disconnect switch or circuit breaker (customer supplied) must be installed in the electrical service line supplying this dishwasher and should meet the requirements of your local electrical code.

ELECTRICAL DATA

Model	Volts/Hertz	Phase	Rated Ampacity	Minimum Supply Circuit Conductor Ampacity	Maximum Protective Device Ampacity
H60-DT/ST/CT	208-240/60	3Ø	36.8	40	40
H60-D1/S1/C	208-240/60	3Ø	28	40	40
H60-DT2/ST2/CT2	208-240/60	1Ø	32	40	40

Compiled in accordance with the National Electrical Code NFPA-70 (latest addition).

4. Operating Instructions(continued)

4.17.2 Electrical Connection (H60-DT/ST/CT/H60-D1/S1/C)

Remove the rear panel by removing the eight screws at the panel.

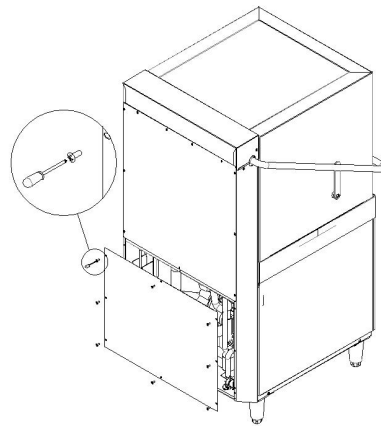
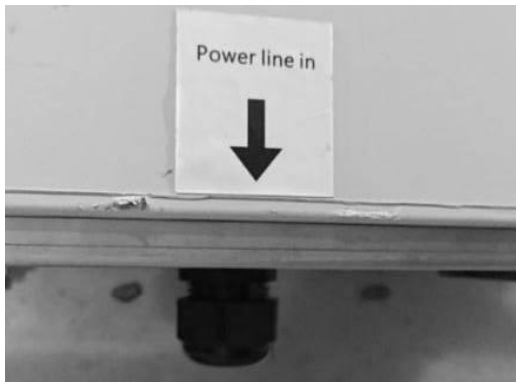

Make electrical connections according to wiring diagram supplied with the machine and secure wires to the machine service connection. Recommended wire specification as 4*9 AWG or 4*10 AWG. Keep excess wire in the base of the unit to a minimum.

A cable support and hole for astrain relief are supplied to facilitate wire routing

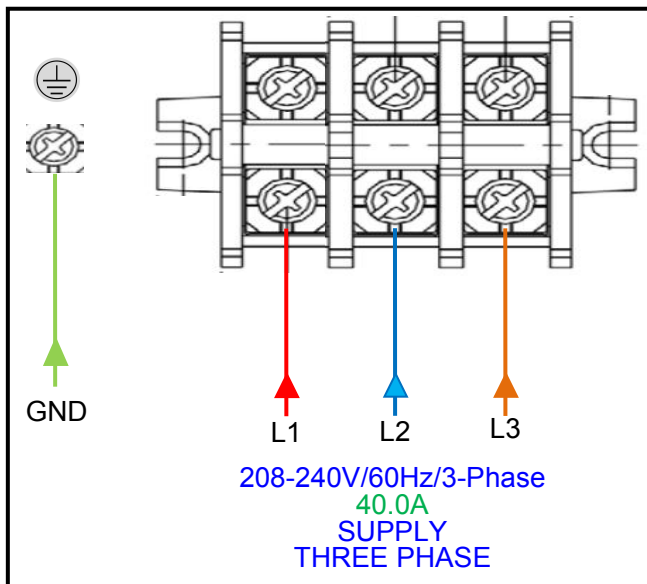

Remove the screws on the front panel, locate the air circuit breaker and open it

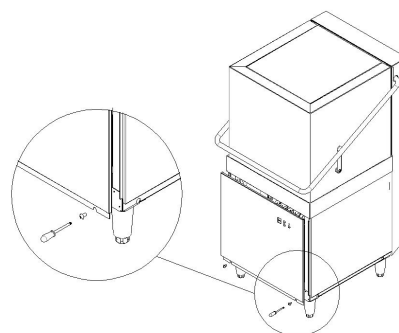

4、 Operating Instructions(continued)

4.17.3 Electrical Connection (H60-DT2/ST2/CT2)

Remove the rear panel by removing the eight screws at the panel.

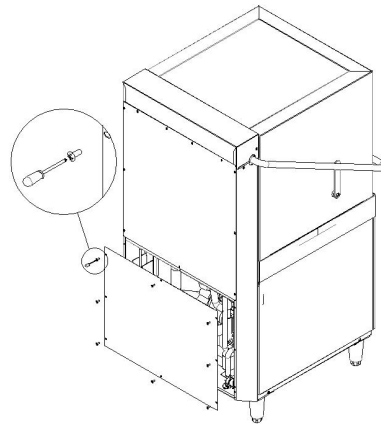
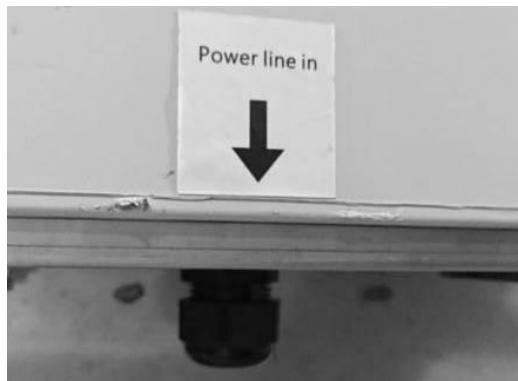

Make electrical connections according to wiring diagram supplied with the machine and secure wires to the machine service connection. Recommended wire specification as 3*9 AWG or 3*10 AWG. Keep excess wire in the base of the unit to a minimum.

A cable support and hole for astrain relief are supplied to facilitate wire routing

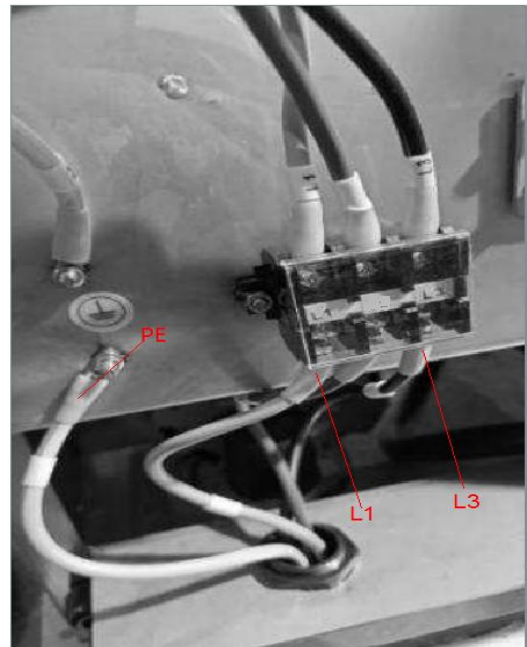
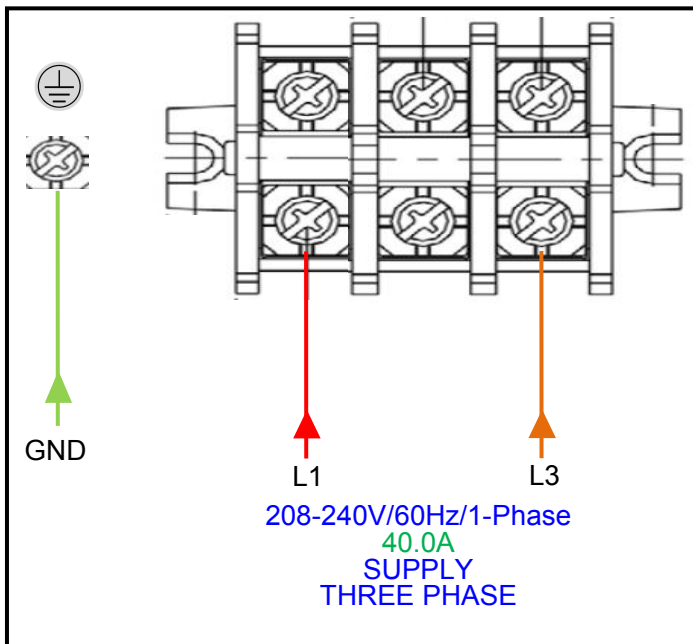

Remove the screws on the front panel, locate the air circuit breaker and open it

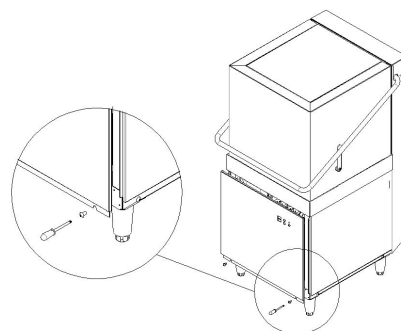

4. Operating Instructions(continued)

4.18 CHEMICAL SUPPLY SET UP

4.18.1 Personnel qualification

Setup must only be carried out by qualified personnel (see section)

4.18.2 Checking the chemical supply tubing

checking the chemical supply tubing:

The chemical tubing with 94.85" long assembled in the base of the machine.

Check chemical labels:

- ⇒ The clear tubing – Detergent
- ⇒ The clear tubing – Rinse Aid



4.18.3 Setup of external chemical bottles/buckets

Preparing the detergent, rinse aid

Suction height of detergent, rinse aid pumps: max. 5 ft

Standard suction tubes

Standard suction tubes

Place clear suction tubing marked for detergent at the bottom of the detergent bottle/bucket.

Place clear suction tubing marked for rinse aid at the bottom of the rinse aid bottle/bucket.

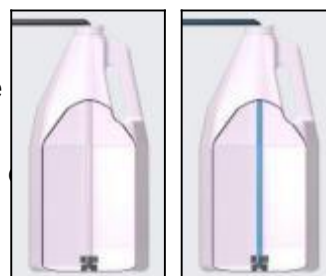

4.18.4 Filling chemical tubing



WARNING!

Chemical burns, irritation of the skin

Filling the chemical tubing with detergent, rinse aid for the first time incorrectly can cause serious injury.

Wear protective equipment (gloves, safety goggles, protective clothing) when handling chemicals.

Observe the manufacturer's application and safety instructions.



4. Operating Instructions(continued)

4.19 OPERATION

4.19.1 Personnel qualification

The machine must be operated by qualified personnel.

4.19.2 Special safety instructions

WARNING!

Chemical burns, irritation of the skin, scalding

If the door is opened during operation, wash water can spray out and cause injury.

Do not open the door during operation, wait for the cycle to finish.



4.19.3 Notes for optimal washing result

The rinse result is significantly affected by the water quality. If the mineral content is high, the minerals dissolved become visible on the glasses in the form of spots and streaks during the drying process.

Recommended water hardness is 3 grains of hardness per gallon or less. Higher hardness may cause excessive formation of lime scale. Water hardness above 3 grains per gallon requires water treatment.

If you have any questions, please contact your authorized our company service partner.

4.19.4 Preparation for washing

Preparing the machine

Check correct position of drainage filter screen and main washing filter screen and proper installation of upper and lower wash/rinse arms.

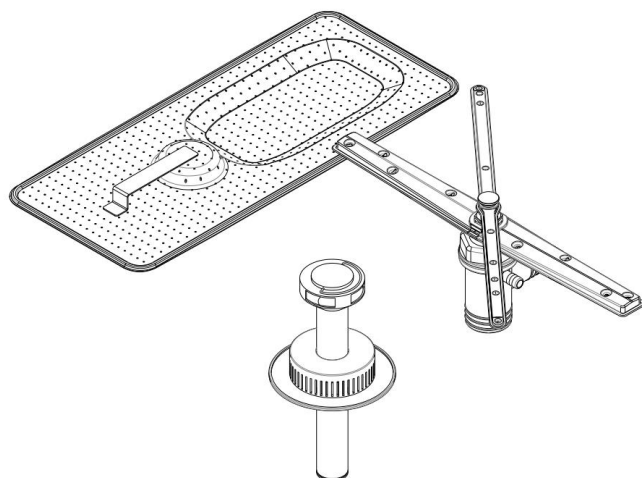

Open building water shut-off valve.

4、 Operating Instructions(continued)

Turn on main switch or breaker.

Check level of detergent and rinse aid in containers

Close door.

Press the On /Confirm Button.



⇒ During the filling and heating processes, the indicator lighting flashes.



ATTENTION:

H60-DT/D1/DT2 model, BEFORE FIRST USE, YOU NEED TO MAKE SURE WATERTANK IS FILLED AND THEN CONNECT TERMINAL 3 AND TERMINAL 4 TO ACTIVATE HEATING ELEMENT.

FOR MAINTAINING OR REPAIRING HEATING ELEMENT DISCONNECT TERMINAL 3 AND TERMINAL 4 AFTER DRIANED WATER TANK OR BOOSTER. AFTER MAINTAINING OR REPAIRING COMPLETED, CONNECT TERMINAL 3 AND TEMINAL 4 WHEN WATER TANK FILLED.

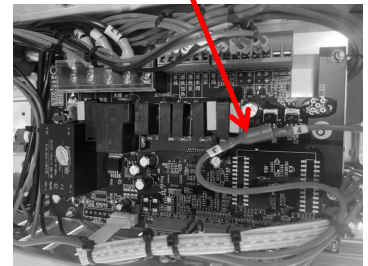

⇒ To achieve the best washing effect, that is, when the temperature reaches and The green light is on, to operation.

4.19.5 Preparing the ware for washing

Remove heavy food residue.

Load ware into rack.

Rinse off ware.

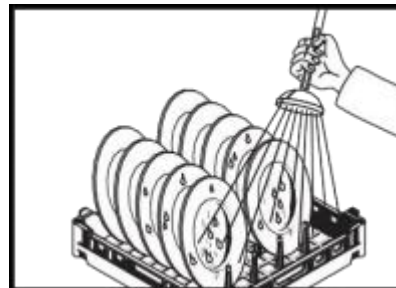
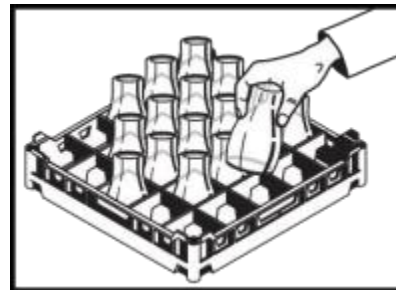

Never use steel wool on ware to be loaded into the dish machine.

4. Operating Instructions(continued)

4.20 Washing

Open door.

Slide rack into the machine and close the door. The wash cycle will start automatically.

⇒ While the washing cycle is running, the indicator LED shining base on the washing process, As soon as the indicator LED turn off, the washing cycles is completed.

Open the door and remove the rack.

Allow the ware enough time to dry.

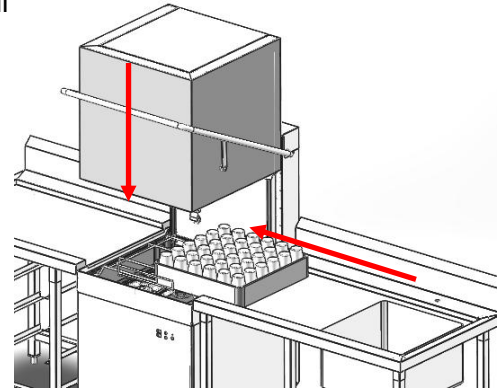

4.21 Switch off machine

Press the power off button



Remove any heavy food residues.

Drain the wash tank by pulling out the rod

Turnoff main switch or breaker.

Close building water shut-off valve.

4.22 Daily cleaning or after each meal period

NOTICE!

Property damage

The use of unsuitable agents can cause corrosion damage.

Do not use any bleach, acids, or metal-containing additives to clean the machine.

Do not use metal brushes.

4. Operating Instructions(continued)

Open the door, remove main washing filter screen and drainage filter screen. Rinse under running water. Make sure that food debris does not enter pump intake when the pump strainer is removed.

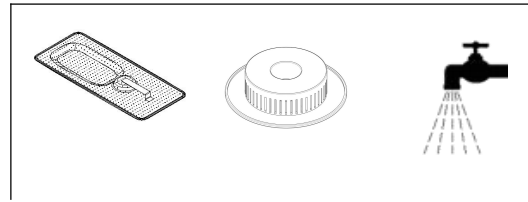

4.23 SETTINGS

4.23.1 Overview of operator menu

Item	Menu Function	Setting (default)
d1	Cycle 1 Wash time	55 seconds
d2	Rinse start waiting time	3 seconds
d3	Rinse time	12 seconds
d4	Rinse Aid feeding time	8 seconds (should less than d3)
d5	Detergent feeding time	5 seconds (should less than d1)
d6	Maximum duration for wash tank fill	10 minutes
d8	Cycle 2 Wash time	85 seconds
d9	Cycle 3 Wash time	115 seconds
C1	Wash tank heating off temperature	161 °F
C2	Wash tank heating on temperature	156 °F
C3	Rinse booster heating off temperature	181 °F
C4	Rinse booster heating on temperature	176 °F
CA	Detergent concentration	70% of detergent pump output voltage
CB	Rinse aid concentration	70% of rinse aid pump output voltage
CD	Fill after machine startup	2 seconds
CE	Detergent feeding time for 1 st wash cycle	3 seconds
CF	Rinse aid feeding time for 1 st wash cycle	3 seconds
A3	Heating method	0 apply to H60-DT/ST/CT/DT2/ST2/CT2
		1 apply to H60-D1/S1/C
A6	Drainage action 1	0 apply to H60-DT/ST/D1/S1/DT2/ST2
		35 apply to H60-CT/C/CT2
A7	Drainage action 2	0 apply to H60-DT/D1/DT2
		30 apply to H60-ST/CT/S1/C/ST2/CT2
A8	Drainage action 3	0 apply to H60-DT/ST/D1/S1/DT2/ST2
		35 apply to H60-CT/C/CT2
L6	Celsius/Hua Celsius	1: Hua Celsius degree

Some codes are not displayed in this table and are not applicable to this product model. Consumers can ignore them.

4、 Operating Instructions(continued)

4.23.2 Opening the operator menu

Note: Machine must be in ready (idle) state.

Press the Menu button by 7 seconds to access operator program settings.

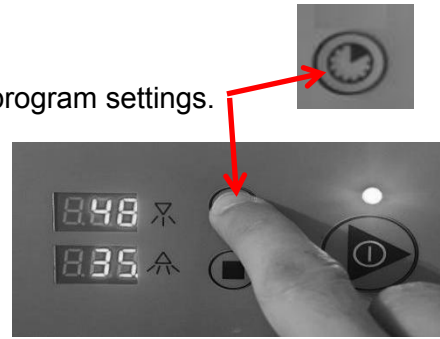

⇒ The menu opens, temperature display will turn to item and parameter

⇒ The upper display will show the first item "d1", and lower display will show parameter

To scroll from one item to the next, press the menu button. After the last item, the sequence will return to the first item.

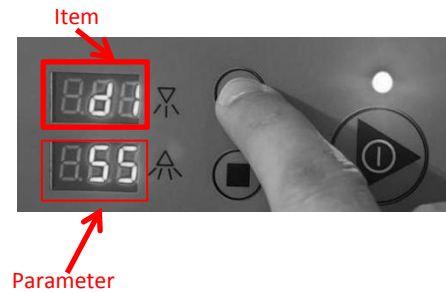
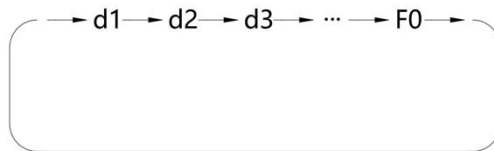

Short press Confirm Button to adjust the parameter

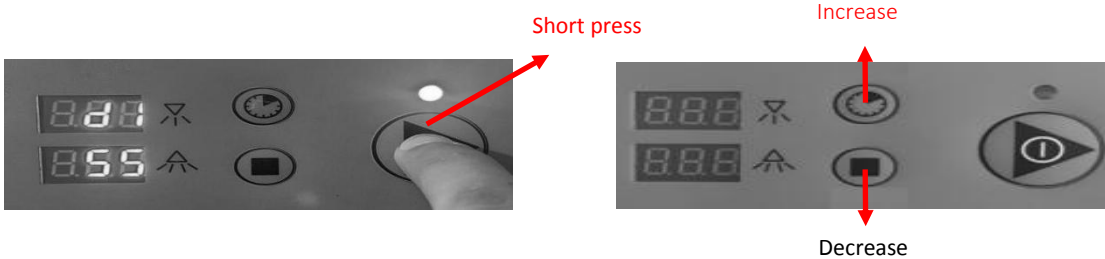

To save and exit the operator menu at anytime, press Confirm Button for 3 seconds.

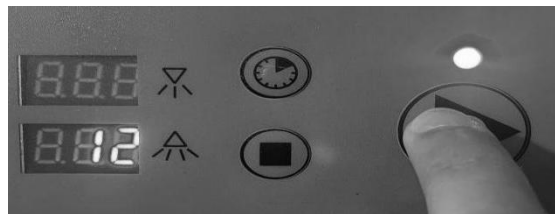

4、 Operating Instructions(continued)

4.24 Detergent and Rinse Aid Dispensing

4.24.1 Setting detergent dispensing

Flow speed for detergent pump is 4ml/second, formula will be $\frac{4 \times CA}{100} \times d5$

For example CA=60, d5=3 each wash cycle dispensing 7.2ml

To adjust dosage, just increase or decrease CA Parameter

4.24.2 Setting rinse aid dispensing

Flow speed for rinse aid pump is 1.5ml/second, formula will be $\frac{1.5 \times CB}{100} \times d4$

For example CB=60, d4=8 each resin cycle dispensing 7.2ml

To adjust dosage, just increase or decrease CB parameter

4.24.3 Priming detergent and rinse aid dispensing pump

Turn on main switch or breaker, machine on switch off state

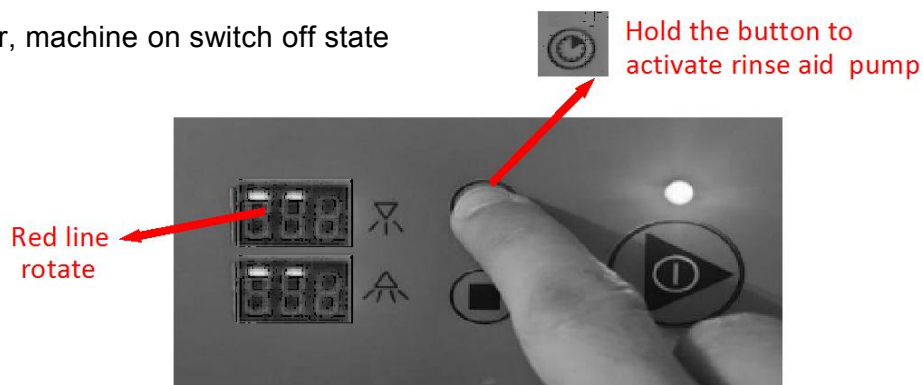

Verify the detergent or rinse aid is moving from the detergent/resin aid bottle or container to the machine.

Multiple operations may be required until the pipeline is filled with medication .



5. Cleaning and Maintenance

5.1 Weekly cleaning

Disassembly the lower wash and rinse arm by anticlockwise

Remove and clean wash and rinse arm.

Repeat for upper arm

Replace all parts.

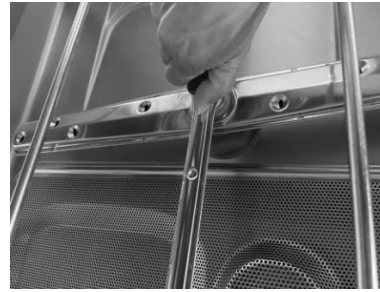

5.2 Removing hard water deposits (Deliming)

The dishwasher should be delimed on a regular basis as required. How often depends on the mineral content of the water. Deliming should be done when you can see clear signs of lime deposits (a white chalky substance) on the inside walls, on the wash and rinse arms or tank heater. Inspect the machine interior for lime deposits. When deliming is necessary, a deliming agent (such as Lime-A-Way® or LSR®) should be used for best results.

WARNING!

Chemical mixing



Deliming solution must not come in contact with bleach or rinse solution containing bleach. Mixing may cause hazardous gas to form. This entire procedure must be followed step-by-step for safe and satisfactory results.

6、 Troubleshooting

6.1 Information

The error code is shown in the bottom display (see table).

Error code	Symptom	Possible Solution*
E1	Rinse Temperature Sensor Open Circuit	1. Check whether the line loose or disconnected 2. Check sensor burn out or damage 3. If error continues to display – contact qualified service person
E2	Rinse Temperature Sensor Short Circuit	
E3	Wash Temperature Sensor Open Circuit	
E4	Wash Temperature Sensor Short Circuit	
E7	Wash Tank Fill Time Exceeded	1. Switch off the machine, pull out the rod and drain, then restart 2. Check whether the water level pressure sensor fault 3. If error continues to display – contact qualified service person
E9	Overheat fault	1. Check overheat switch open circuit or short circuit. 2. If error continues to display – contact qualified service person
EC	Wash heater fault	1. Verify whether controller or contactor fault 2. Replace heater 3. If error continues to display – contact qualified service person
ED	Rinse heater fault	

6. Troubleshooting(continued)

6.2 TROUBLESHOOTING GUIDE

6.2.1 Poor wash results

Fault Type	Possible Cause	Remedy
Ware not clean	Was hard to turn (must rotate easily by hand).	<ul style="list-style-type: none"> Remove wash arms and clean them thoroughly. Also check that water manifold from machine to wash arm is clear.
	Wash arm nozzles are clogged (visual check).	<ul style="list-style-type: none"> Remove wash arm and rinse wash arm thoroughly until all soiling is removed.
	Rinse nozzles clogged (usually by lime deposit).	<ul style="list-style-type: none"> Remove rinse arms and delime them in separate container. Check building softening system for function. Delime machine if needed.
	Detergent concentration is too low or too high.	Check detergent concentration setting (See operating instructions).
	Tank strainers clogged.	Remove strainer pan(s), empty and clean strainer(s).
	Pump strainer clogged.	Remove, empty and clean strainer.
	Wrong program selected for heavily soiled wash ware.	Extend the wash program for longer wash cycle.
Ware or glasses dry poorly	Rinse aid concentration too low.	Increase concentration (see operating instructions)
	Wash ware still greasy.	Detergent concentration too low: increase (see operation instructions). Check if detergent is appropriate. If not, choose a stronger one. Drain contaminated water and refill machine. Ensure better pre-scraping of the wash ware.
	Wash ware left in machine too long after the end of wash cycle.	Remove wash ware as soon as cycle is completed when ware is at its highest temperature to enable better drying.
Streaks and spots on ware or glasses	Rinse aid concentration too high (stripe or bubble formation)	Reduce rinse aid concentration (see operating instructions)
	Hard water or high mineral content.	Check water quality.
	Improper rinse aid	Consult your local chemical provider
	Inadequate rinse aid dispensing causes stains.	Increase rinse aid concentration (see operating instructions)

Important

Retain proof of original purchase to establish warranty period. our company's liability on any claim of any kind, with respect to the

goods and/or services provided, shall in no event exceed the value of the goods or service or part thereof which has given rise to the claim.

30-Day Cosmetic Warranty

The Purchaser must inspect the product at the time of delivery. our company warrants that the Product is free from manufacturing defects in materials and workmanship for a period of thirty (30) days from date of the original retail purchase of the Product.

This coverage includes:

- Paint blemishes
- Chips
- Macroscopic finish defects

Cosmetic warranty does NOT cover:

- Issues resulting from incorrect transport, handling and/or installation (e.g.: dents, broken, warped or deformed structures or components, cracked or otherwise damaged glass components);
- Slight color variations on painted/enamelled components;
- Differences caused by natural or artificial lighting, location or other analogous factors; > stains/corrosion/discoloration caused by external substances and/or environmental factors;> labor costs, display, floor, B-stock, out-of-box,"as is" appliances and demo units.

How to receive service

To receive warranty services, the Purchaser must contact the our company Support department in order to determine the problem and the required service procedures. Troubleshooting with

THERE ARE NO EXPRESS WARRANTIES OTHER THAN THOSE LISTED AND DESCRIBED ABOVE, AND NO WARRANTIES, EITHER EXPRESS OR IMPLIED, INCLUDING, BUT NOT LIMITED TO, ANY IMPLIED WARRANTIES OF MERCHANTABILITY OR FITNESS FOR A PARTICULAR PURPOSE THAT SHALL APPLY AFTER THE EXPRESS WARRANTY PERIODS STATED ABOVE, AND NO OTHER EXPRESS WARRANTY OR GUARANTEE GIVEN BY ANY PERSON, FIRM

OR CORPORATION WITH RESPECT TO THIS PRODUCT SHALL BE BINDING ON our company. our company SHALL NOT BE LIABLE FOR LOSS OF REVENUE OR PROFITS, FAILURE TO REALIZE SAVINGS OR OTHER BENEFITS, TIME AWAY FROM WORK, MEALS, LOSS OF FOOD OR BEVERAGES, TRAVELING OR HOTEL EXPENSES, EXPENSES TO RENT OR PURCHASE APPLIANCES, REMODELING/CONSTRUCTION EXPENSES IN EXCESS OF DIRECT DAMAGES WHICH ARE UNDENIABLY CAUSED EXCLUSIVELY BY our company OR ANY OTHER SPECIAL, INCIDENTAL OR CONSEQUENTIAL DAMAGES CAUSED BY THE USE, MISUSE OR INABILITY TO USE THIS PRODUCT, REGARDLESS OF THE LEGAL THEORY ON WHICH THE CLAIM IS BASED, AND EVEN IF our company HAS BEEN ADVISED OF THE POSSIBILITY OF SUCH DAMAGES. NOR SHALL RECOVERY OF ANY KIND AGAINST our company BE GREATER IN AMOUNT

THAN THE PURCHASE PRICE OF THE PRODUCTSOLD BY our company AND CAUSING THE ALLEGED DAMAGE. WITHOUT PREJUDICE TO THE FOREGOING, PURCHASER ASSUMES ALL RISK AND LIABILITY FOR LOSS, DAMAGE OR INJURY TO PURCHASER AND PURCHASER'S PROPERTY AND TO OTHERS AND THEIR PROPERTY ARISING FROM THE USE, MISUSE, OR INABILITY TO USE THIS PRODUCTSOLD BY our company THAT IS NOT A DIRECT RESULT OF NEGLIGENCE ON THE PART OF our company THIS LIMITED WARRANTY SHALL NOT EXTEND TO ANYONE OTHER THAN THE ORIGINAL PURCHASER OF THIS PRODUCT, IS NON-TRANSFERABLE, AND STATES YOUR EXCLUSIVE REMEDY.