

# Instruction Manual of RC100B20



Read the instructions carefully before using the product, and reserve them properly.

## Table of Contents

1. Name of parts
2. Product Specification Table
3. Cautions of safe use
4. Usage method
5. Display status and description
6. Cleaning and maintain
7. Product fault Code table
8. Fault and solution
9. Electrical sketch
10. Maintenance Service Assurance

# RC100B20 说明书

## Name of parts

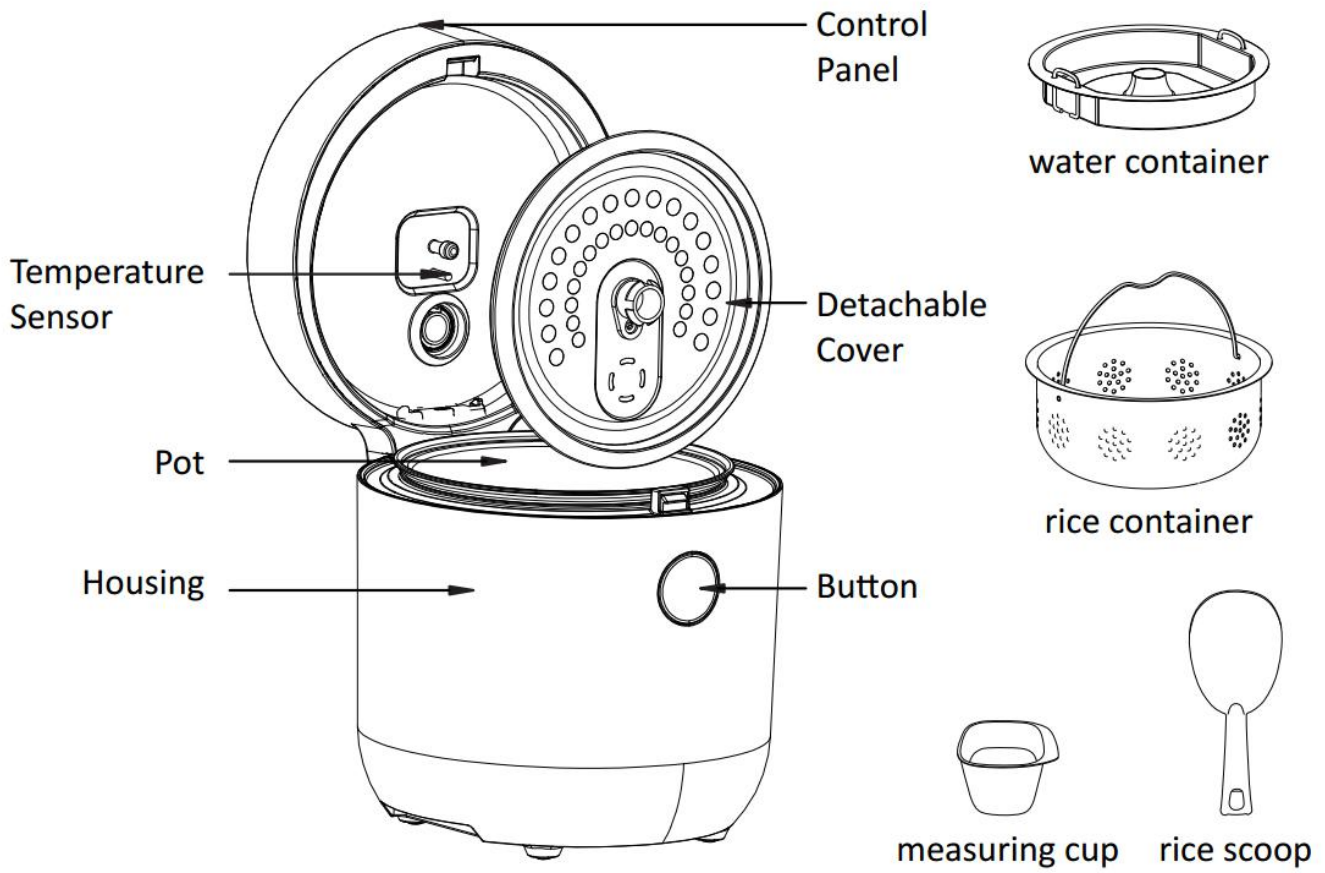

## Product Specification Table

Model No.	RC100B20
Voltage/frequency	220V-240V~ 50/60Hz
Rated power	500W
Heating mode	Heating plate
Gross weight	3.0 Kg
Net weight	2.1kg
Product size	223×234×220mm
Rated capacity	2.0L
Suitable number	3-4 persons
Energy efficiency grade	2

## *Cautions of safe use*

### **Using environment**

1. The normal working elevation range of the product is 0-2000 meters.
2. Do not place the product in an unbalanced, humid or near other sources of fire, heat sources (such as furnaces), preferably at a distance of more than 30 cm.
3. Because steam and heat can cause damage, discoloration and deformation of walls and furniture, please use more than 8 cm away from walls and furniture.
4. Keep ventilated when put into cabinets and other places.
5. Do not place this product on a soft surface (such as carpets, rags, etc.).
6. This product should avoid direct sunlight.
7. This product is only for indoor use.

### **Cautions for Power Supply**

1. It is forbidden to use power sources other than 220V AC in order to avoid fire.
2. Be sure to use sockets with grounding wires above rated current 10A separately, so as not to cause fire and other dangers.
3. Do not use wet hand plugs or power cord plugs when there are water marks, please clean them in time before they can be used.
4. Do not use it by children alone. It must be kept out of reach of infants to avoid electric shock, scald and other dangerous accidents.
5. If the power cord is damaged, please contact the local after-sales service point for replacement. Do not replace it by yourself.
6. Be sure to disconnect the AC power line on the AC power socket before performing maintenance operations, checking for faults or moving.
7. Do not over twist, bend or twist AC power lines, otherwise the cores may be exposed or broken.

### **When in use**

1. Do not place the inner pot on other heat sources for heating (such as induction cooker, gas cooker)
2. Only the inner pot attached to this product can be used, and can not be replaced by other manufacturers or other inner pots, in order to avoid product failure or danger.
3. Do not start the operation when the inner pot is not put into the main machine or when the inner pot is empty.
4. Do not put any food or water in the main machine before the inner pot is put into the main machine.
5. Do not remove the inner pot when the product is working, in order to avoid danger.
6. The product will produce high temperature and steam when used. Keep your hands and face away from steam holes to prevent scalds.
7. Do not cover the cloth and other articles on the steam holes in order to avoid deformation of the upper cover and product failure. Do not use this product in high temperature and humidity.
8. Do not wash rice in the inner pot, should be placed in other containers after cleaning and poured into the inner pot of this product, in order to avoid the deformation of the inner pot, non-stick coating scratches.
9. If the inner pot is deformed, please do not continue to use it. Contact our after-sales service personnel to purchase new inner pot.
10. Before putting the inner pot into the body, please confirm whether there is any sticking of rice grains or other vegetable residues on the bottom of the inner pot and the heating plate. If you have to remove them first, then put them into the inner pot.
11. After the inner pot is put in, it must be rotated around to ensure that the inner pot and the heating plate

# RC100B20 说明书

are fully adhered to each other.

## Daily maintenance

1. Before cleaning this product, please confirm that the power plug has been pulled out of the power socket, and wait for it to be completely cooled before cleaning this product.
2. When cleaning this product, do not immerse the product in water or wash it under the tap.
3. The anti-spill cover and steam cover should be cleaned regularly to avoid the odor and clogging of rice.
4. When not in use for a long time, the plug should be pulled out of the socket and stored in a ventilated and dry place.
5. If the power cord or plug is found to be damaged or broken, do not continue to use this product. It must be replaced with special soft wires or special components purchased from its manufacturer or designated maintenance department.
6. If any malfunction occurs, please turn off the power supply and pull the plug out of the socket. Do not continue to use the plug. Contact our after-sales service personnel. Do not replace non-original parts or disassemble and repair by yourself.

## Usage Method

- Please read this manual carefully before using it.
- Before plugging in the plug, please make sure that the outlet voltage in the home is in accordance with the product.
- Before the first use, please take out all the packaging items on the product, and remove the inner pot, overflow-proof cover plate and steam valve and put them under the tap for cleaning.
- Before putting the inner pot into the body, please confirm whether there is any sticking of rice grains or other vegetable residues on the bottom of the inner pot and the heating plate. If there is any need to clear the inner pot before putting it into the inner pot, then rotate around to ensure that the inner pot and the heating plate are fully adhered to each other.
- Description of Interface Functions:

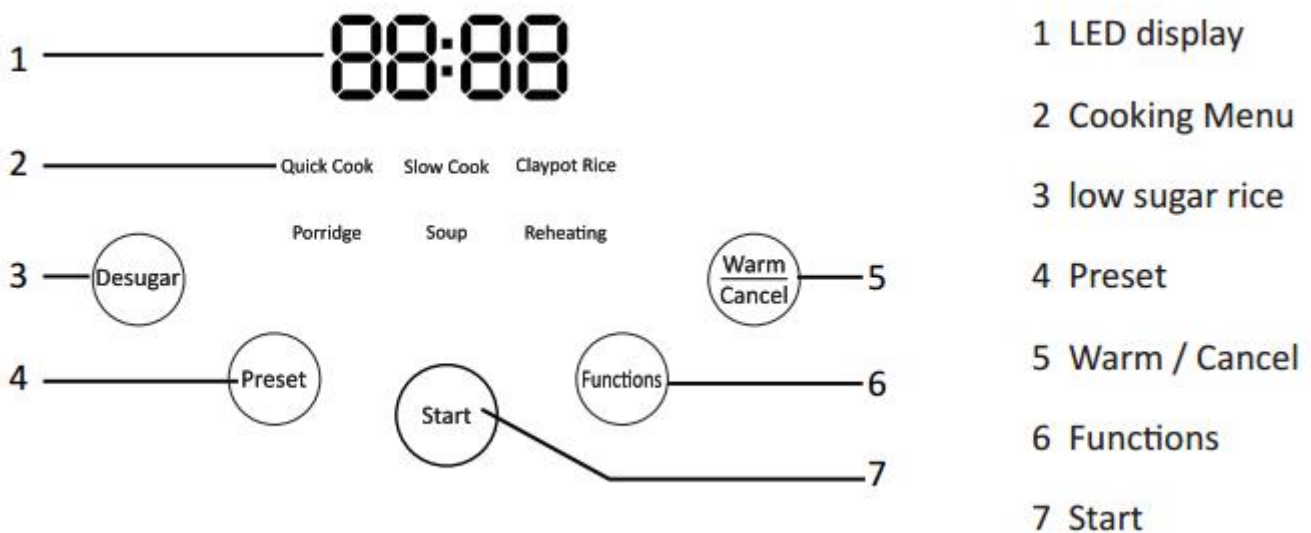

Quick Cook

## RC100B20 说明书

- The maximum boiled rice content of this product is 4 cups of rice. It is recommended that the ratio of rice to water be 1 cup of rice and 1.1 cup of water. The ratio of rice to water should not exceed the maximum boiled rice content (the above ratio of rice to water can be adjusted according to individual preferences).
- Press "Functions" button to select "Quick Cook" function.
- Complete the required settings, press the start button, 5 seconds later 2 beeps into the corresponding functional work process, the display screen shows the horse-running lamp, cooking function key display lamp is always on.
- After the setting function is completed, the cooker automatically enters the heat preservation state, the buzzer sounds 4 times, and the heat preservation lamp lights up at the same time.
- **Maximum cooking time will be 30mins to 45mins ( Different kind of rice, different capacity of rice and water, time is different).**

### Slow Cook

- The maximum boiled rice content of this product is 4 cups of rice. It is recommended that the ratio of rice to water be 1 cup of rice and 1.1 cup of water. The ratio of rice to water should not exceed the maximum boiled rice content (the above ratio of rice to water can be adjusted according to individual preferences).
- Press "Functions" button to select "Slow Cook" function.
- Complete the required settings, press the start button, 5 seconds later 2 beeps into the corresponding functional work process, the display screen shows the horse-running lamp, cooking function key display lamp is always on.
- After the setting function is completed, the cooker automatically enters the heat preservation state, the buzzer sounds 4 times, and the heat preservation lamp lights up at the same time.
- **Maximum cooking time will be 35mins to 50mins ( Different kind of rice, different capacity of rice and water, time is different).**

### Claypot Rice

- Press the "Function" button and select Claypot Rice function.
- Setting time is show **70 mins** ( Different kind of rice, different capacity of rice and water, time is different), not need to setting again, just press "Start". 5 seconds later, it will enter into the workin process after 2 beeps. The time on show is countdown mode, and the light of the "Claypot Rice" will be on.
- After the setting function is complete, the cooker will enter to "warming" process with 4beeps, and the light of the warm will be on at the same time.

### Porridge

- Press the "Functions" button and select the "Porridge" function.
- **Cooking time will be 50 mins to 60 mins ( Different kind of rice, different capacity of rice and water, time is different),** complete the required settings, press the start button, enter the corresponding functional work process, 5 seconds later, 2 beeps into the corresponding functional work process, the display screen shows a countdown, the function of cooking porridge key display light is always on.
- After the setting function is completed, the cooker will automatically enter the heat preservation state, the buzzer will ring four times, and the heat preservation lamp will light up.

*Tips: Maximum amount of porridge rice is 2 cups of rice. Proposed ratio of rice to water is 1:8 or 1:10.*

## Desugar

- Press the "Desugar" function button.
- **Cooking time will be 50 mins to 60 mins ( Different kind of rice, different capacity of rice and water, time is different),** complete the required settings, press the start button, enter the corresponding functional work process, 5 seconds later, 2 beeps into the corresponding functional work process, the display screen shows a countdown, the function of cooking porridge key display light is always on.
- After the setting function is completed, the cooker will automatically enter the heat preservation state, the buzzer will ring four times, and the heat preservation lamp will light up.

*Tips: The recommended height of water is over rice about 3mm.*

## Soup

- Press the "Functions" button and select the "Soup" function.
- Default working time is **2 hours**, complete the required settings, press the start button, enter the corresponding functional work process, 5 seconds later, two beeps enter the corresponding functional work process, the display screen shows the countdown, the soup cooker function key display lamp is always on.
- After the setting function is completed, the cooker will automatically enter the heat preservation state, the buzzer will ring four times, and the heat preservation lamp will light up.

## Reheating

- Press "Functions" button and select "Reheating" function
- Default working time is **20** minutes, complete the required settings, press the start button, enter the corresponding functional work process, 5 seconds later, two beeps enter the corresponding functional work process, the display screen shows the horse-running lamp, reheating function key display lamp is always on.
- After the setting function is completed, the cooker will automatically enter the heat preservation state, the buzzer will ring four times, and the heat preservation lamp will light up.

## Preset

- The reservation time of this product is 24 hours, and the reservation time of this product is the **start time of cooking.**
- The appointment time should not be too long, so as to avoid the production of odors, it is recommended not to exceed 12 hours.
- Press the "function" button to select the "cooking" function, and then select the "Preset" button. When the "Preset" indicator is on, press "Preset" to increase the time. Within 10 hours, it will increase by 0.5 hours, and after 10 hours, it will increase by 1 hour.
- After setting the appointment time, press the "Start" button or wait for 5 seconds and then ring 2 beeps to enter the working process of the corresponding function. Or, the "Preset" function and the cooking function are kept on bright at the same time.
- **After working time is over,** the rice cooker will automatically enter the heat preservation state, the buzzer will ring **4** times, and the heat preservation light will be on.

# RC100B20 说明书

■ Please refer to the booking schedule.

*Reservation Time Table*

Function	Cooking	Soup	porridge
Time	1.5 Hours-12 Hours	1.5 Hours-24 Hours	1 Hour-12 Hours

## *Display status description*

- In standby state digital tube display "-- --", start indicator light is always on
- Under the reservation state, the digital tube displays the appointment countdown time, the reservation indicator and the function indicator are always on
- The digital tube displays "00:00" under the insulation state. The insulation indicator is always on, and the time is progressive in unit of 1 minute.

## *Cleaning and maintenance*

### **Clean the pot, steamer, aluminum alloy anti - overflow cover**

- Use hot water, dishwashing liquid and sponge to clean the inner pot, steamer and aluminum alloy overflow cover. Do not use detergent or wire pellets.
- If food sticks to the bottom of the inner pot, soak it for a while before cleaning, and then wipe it clean.

### **Maintain inner pot**

- Use a plastic or wooden spoon. Do not use a metal spoon to avoid scratching the surface of the inner pan.
- To protect the life of the non-stick coating as much as possible, cutting food in the inner pan is not recommended.
- To avoid corrosion, do not pour vinegar into the inner pan.

### **Clean and maintain other parts of the cooker**

- Clean the central area, sealing cover and exterior of rice cooker with wet cloth.
- If there is water on the electric heating plate, please wipe it dry with a cloth. If there is burnt rice, please polish it with steel ball or sandpaper.

*Note: please cut off the power before cleaning and clean after the cooker cools to prevent burns.*

## *Product fault code table*

Fault	Fault Code	Reason	Solve
Bottom sensor short circuit	E1	Bottom sensor short circuit	Connect the thermistor correctly(or return to normal temperature), power on again
Bottom sensor open circuit	E2	Bottom sensor open circuit	Connect the thermistor correctly(or return to normal temperature), power on again
Top sensor short circuit	E3	Top sensor short circuit	Connect the thermistor correctly(or return to normal temperature), power on again
Top sensor open circuit	E4	Top sensor open circuit	Connect the thermistor correctly(or return to normal temperature), power on again

## RC100B20 说明书

Over temperature protection	E5	Bottom temperature more than 150°C	Bottom temperature return to lower than protection temperature, power on again
-----------------------------	----	---------------------------------------	--

### *Fault and solution*

Fault phenomenon	Reason	Solve
Light does not shine	1. The board power is not connect 2. Power failure	1 . Check if the product is connected to a power source 2 . Waiting for power
Electric hot plate is not heated	1 . Board failure 2 . Fuse blown 3 . Electric hot plate failure	Contact with the company's service
Light is shine , Electric hot plate is not heated	1 . Electric hot plate failure 2 . Board failure	Contact with the company's service
Uncooked rice	1 . Too much or too little cooking 2 . The ratio of rice and water is incorrect 3 . The inner pot is not placed 4 . There is something between the inner pot and the electric hot plate. 5 . Inner pot deformation 6 . Board failure 7 . Sensor failure	1 . Adjust the total capacity of rice and water, ranging from the highest to the lowest tick 2. Adjust the ratio of rice to water 3. Rotate the inner pot left and right to return it to normal 4. Clean up foreign objects 5. Contact the company's after-sales staff to purchase a new inner pot 6. Contact the company's service point 7. Contact the company's service point
Rice boiled	1 . Inner pot deformation 2 . The inner pot is not placed 3 . Board failure 4 . Sensor failure	1. Contact the company's after-sales staff to purchase a new inner pot 2. Rotate the inner pot left and right to return it to normal 3. Contact the company's service point 4. Contact the company's service point
Overflow	Too much water	Less water
LED panel wrong code: E1, E2, E3 ,E4, E5	Board failure	Contact the company's service point

## Electrical sketch

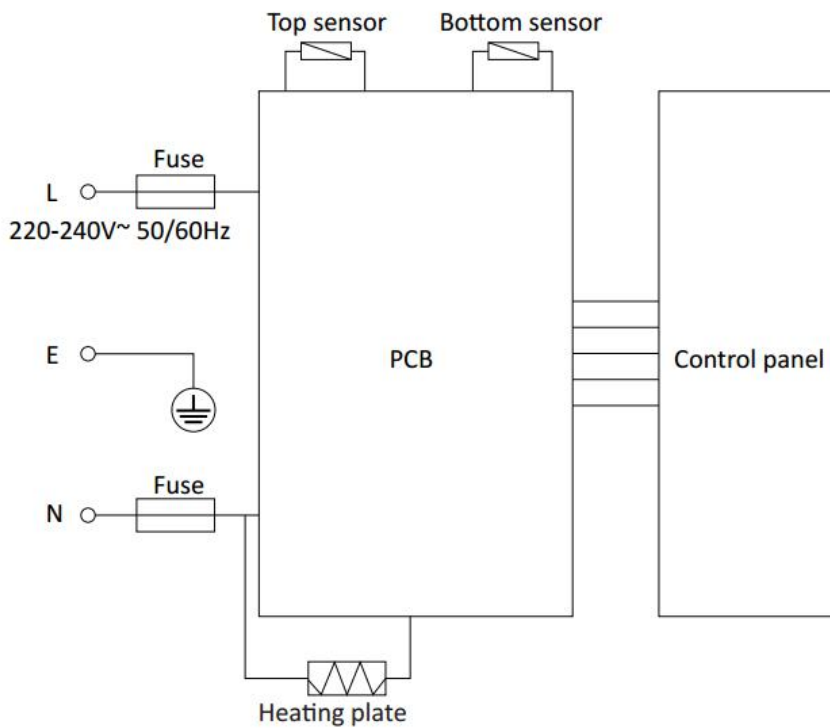

## Maintenance Service Assurance

### Warranty policy

Items	Warranty content	Warranty date
Machine	Machine parts	1Year
Component	Power line, inner pot	1Year

### Effective definition of warranty

1. The date the warranty is received by the consumer receiving the product date
2. The date of receipt of the product cannot be provided, and the date of issue of the valid warranty certificate is the starting date of the warranty period.
3. If there is no valid warranty certificate, it will be 6 months after leaving the factory as the starting date of the warranty period.

### Warranty certificate

1. Product after-sales service valid warranty certificate is the delivery note, purchase invoice, warranty card, network purchase certificate.

## RC100B20 说明书

---

2. Measuring cups, rice spoons and packaging are not covered by the warranty.